

42X AND 45X TECHNICAL DATA

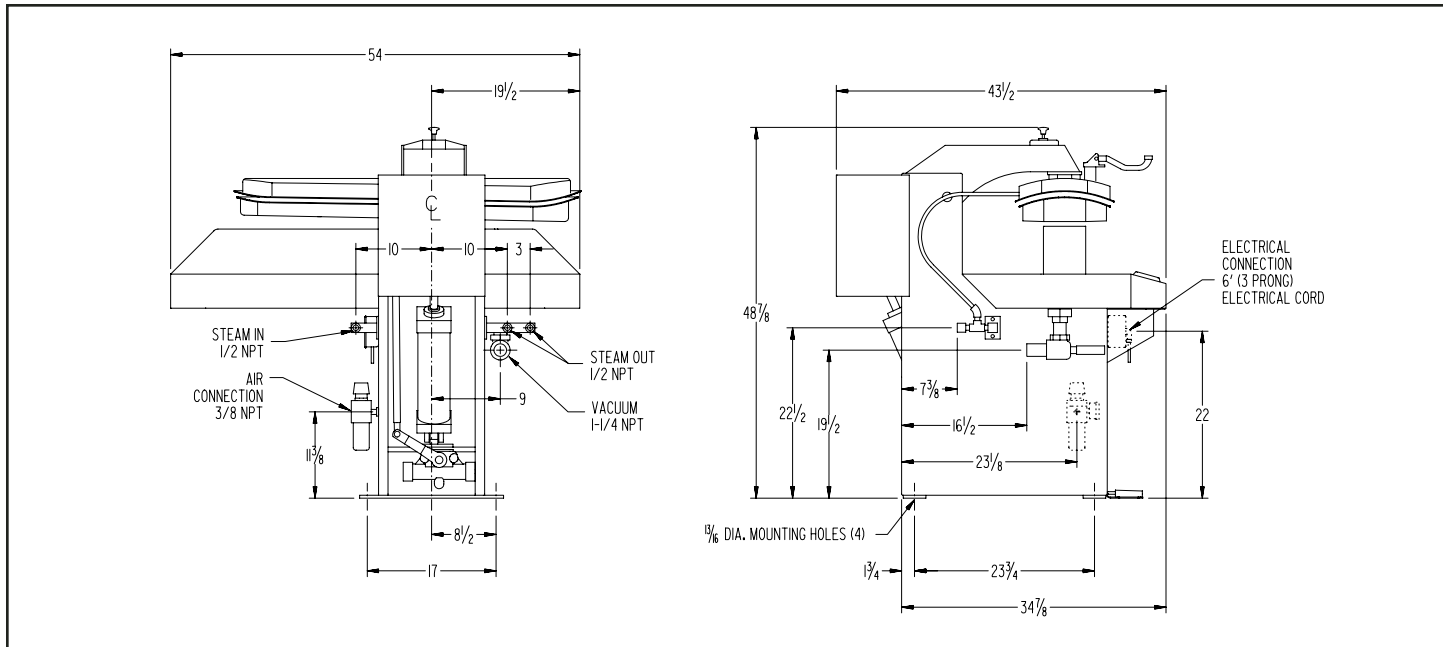

BUCK DIMENSIONS

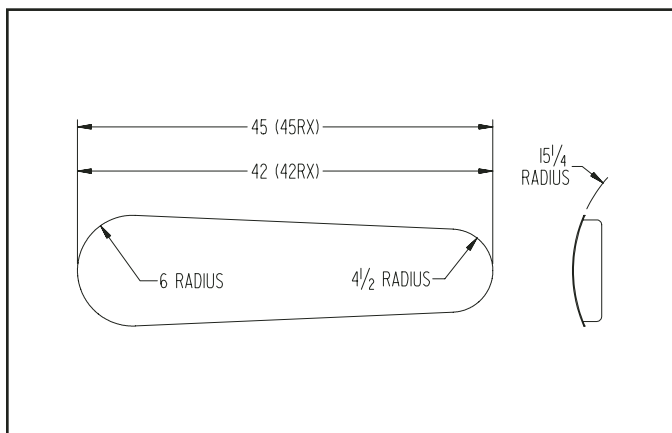

SPECIFICATIONS

	42X	45X
Height of buck - padded	40 1/2"	40 1/2"
Length of buck - unpadded	42"	45"
Width of buck - unpadded	12"	12"
Width of machine	54"	54"
Depth of machine	43 1/2"	43 1/2"
Steam inlet (1)	1/2" NPT	1/2" NPT
Steam outlet (2)	1/2" NPT	1/2" NPT
Vacuum outlet	1 1/4" NPT	1 1/4" NPT
Air inlet	3/8" NPT	3/8" NPT
Air supply	85 PSI	85 PSI
Air consumption/cycle	1/2 Cu. Ft.	1/2 Cu. Ft.
Boiler horsepower rating	1 HP	1 HP
Net weight	750 lbs	800 lbs
Electrical	115/1/60	115/1/60
Amperage	1/2 AMP	1/2 AMP



UNIPRESS

3501 Queen Palm Drive Tampa, Florida 33619
 Telephone (813) 623-3731 FAX (813) 626-2565